

# Digital Image Formation

**Prof. Ioannis Pitas**

**Aristotle University of Thessaloniki**

**[pitas@csd.auth.gr](mailto:pitas@csd.auth.gr)**

**[www.aiia.csd.auth.gr](http://www.aiia.csd.auth.gr)**

**Version 4.4.2**

# Digital Image Formation

- **Image formation**
- Optical sensors and cameras
- Image digitization
- Image noise

# Digital Image Formation

**An image is the optical representation of an object illuminated by a radiating source.**

Image formation involves:

- Object;
- Radiating/illumination source;
- Image formation system (camera).

Primary image formation model:

- visible light reflected on an object.
- Other modes: X-ray, ultrasound, seismic sources.

# Digital Image Formation

- A **still image** visualizes an object or scene at a time instance.
- A **video sequence (moving image)** is the visualization of an object or scene illuminated by a light source, using a moving video camera.
- The captured object, the light source and the video camera can all be either moving or still.
- Thus, moving images are the projection of moving 3D objects on the camera image plane, as a function of time.

# Light reflection

- Objects reflect or emit light.
- **Reflection** can be decomposed in two components:
  - **Diffuse reflection** (distributes light energy equally along any spatial direction, allows perceiving object color).
  - **Specular reflection** (strongest along the direction of the incident light, incident light color is perceived).
- **Lambertian surfaces** perform only diffuse reflection, thus being dull and matte (e.g., cement surface).

# Light reflection

- ***Ambient illumination*** sources emit the same light energy in all directions (e.g., a cloudy sky).
- ***Point illumination*** sources emit light energy isotropically or anisotropically (e.g., ordinary light bulbs) along various directions.
  - If point illumination sources are far away (e.g., sun), their rays are considered to be parallel.

# Light reflection

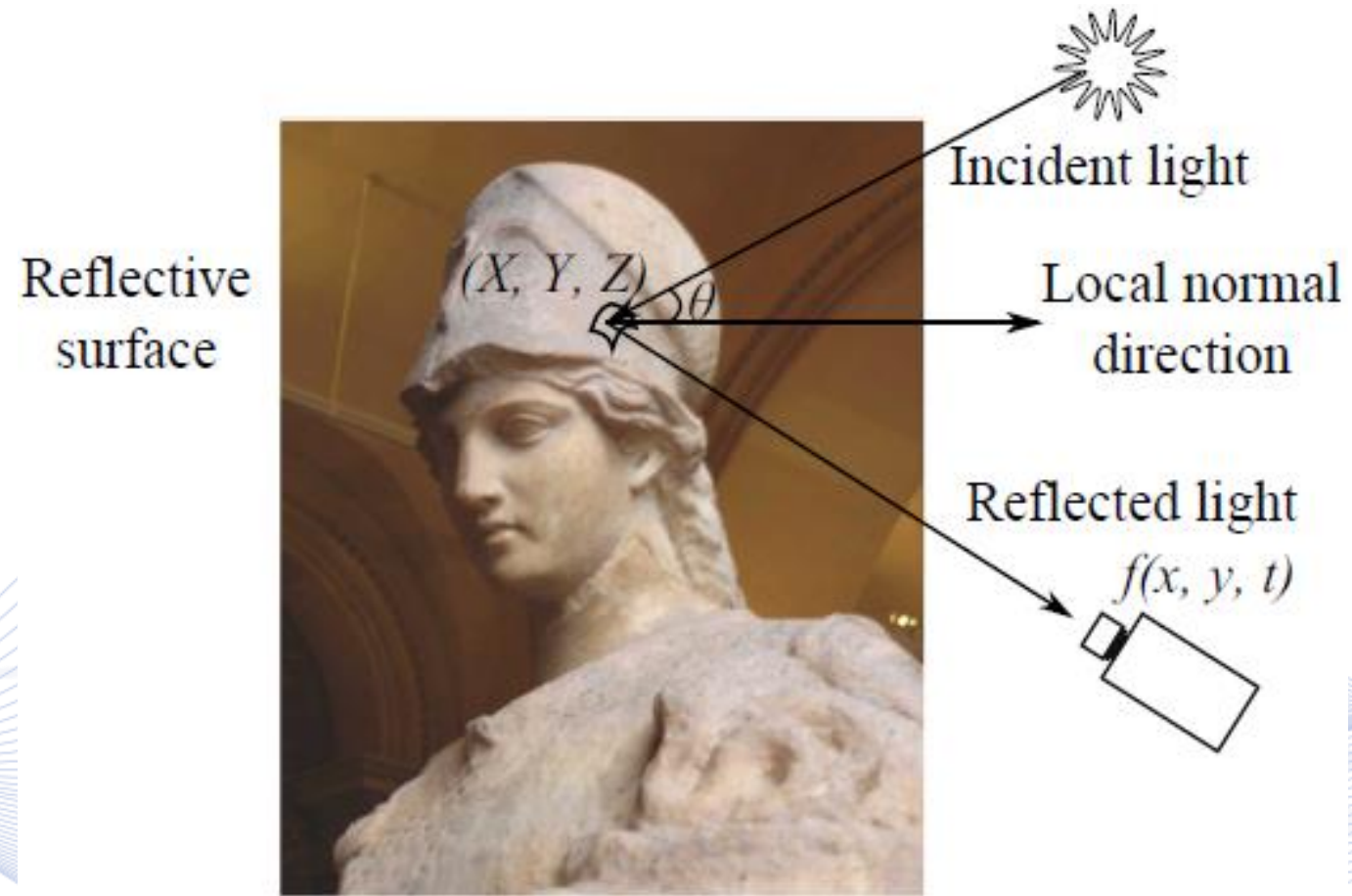

Reflection geometry.

# Light reflection

Reflected irradiance when object surface produces diffuse reflectance and incident light source comes from:

- Ambient illumination:

$$f_r(X, Y, Z, t, \lambda) = r(X, Y, Z, t, \lambda)E_\alpha(t, \lambda).$$

- Point light source:

$$f_r(X, Y, Z, t, \lambda) = r(X, Y, Z, t, \lambda)E_p(t, \lambda) \cos \theta.$$

- Distant point source and ambient illumination:

$$E(t, \lambda) = E_\alpha(t, \lambda) + E_p(t, \lambda) \cos \theta.$$

- This is a special case of ***Phong reflection model***.



# Digital Image Formation

- Image formation
- **Optical sensors and cameras**
- Image digitization
- Image noise

# Pinhole Camera

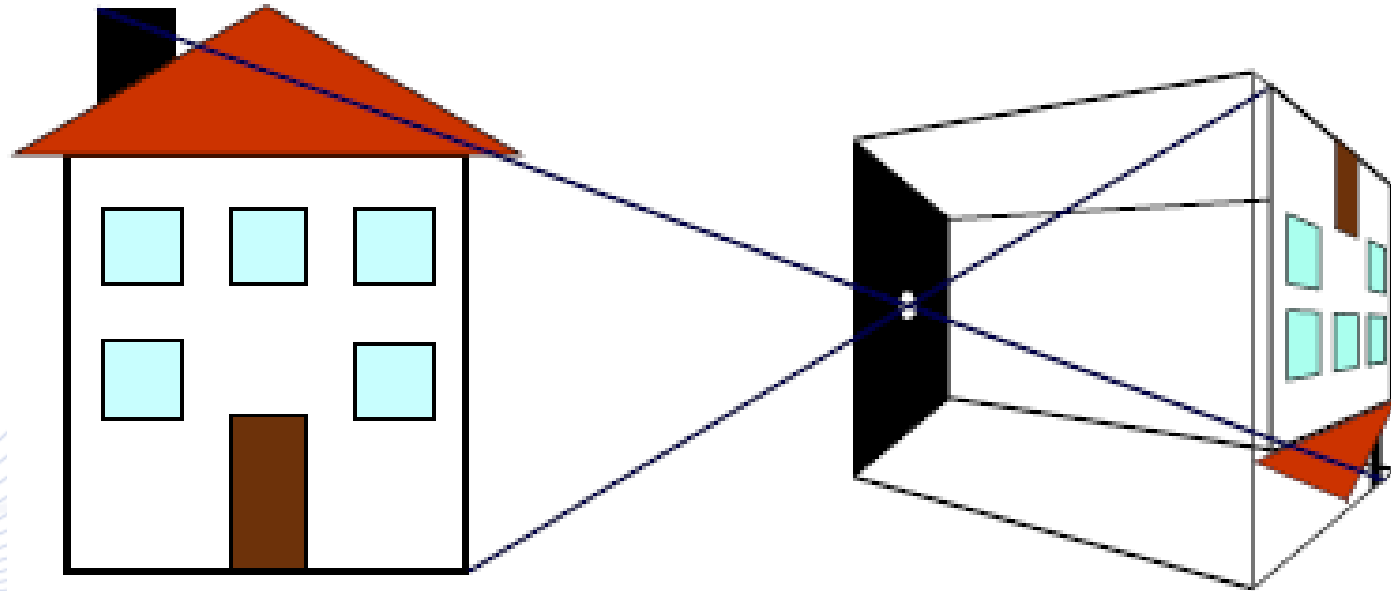

Pinhole camera geometry.

# Camera Structure

- **Lens** is the most important part of the camera.
- Incident light rays pass through a lens (or a group of lenses) and get focused on the semiconductor chip.
- The distance between the lens center (**optical center O**) and the point of convergence of the light rays inside the camera (**focal point F**) is called **focal length  $f$** .
- Focal length characterizes the lens and determines the scene part to be captured as well as scene object sizes (**magnification**).

# Pinhole Camera

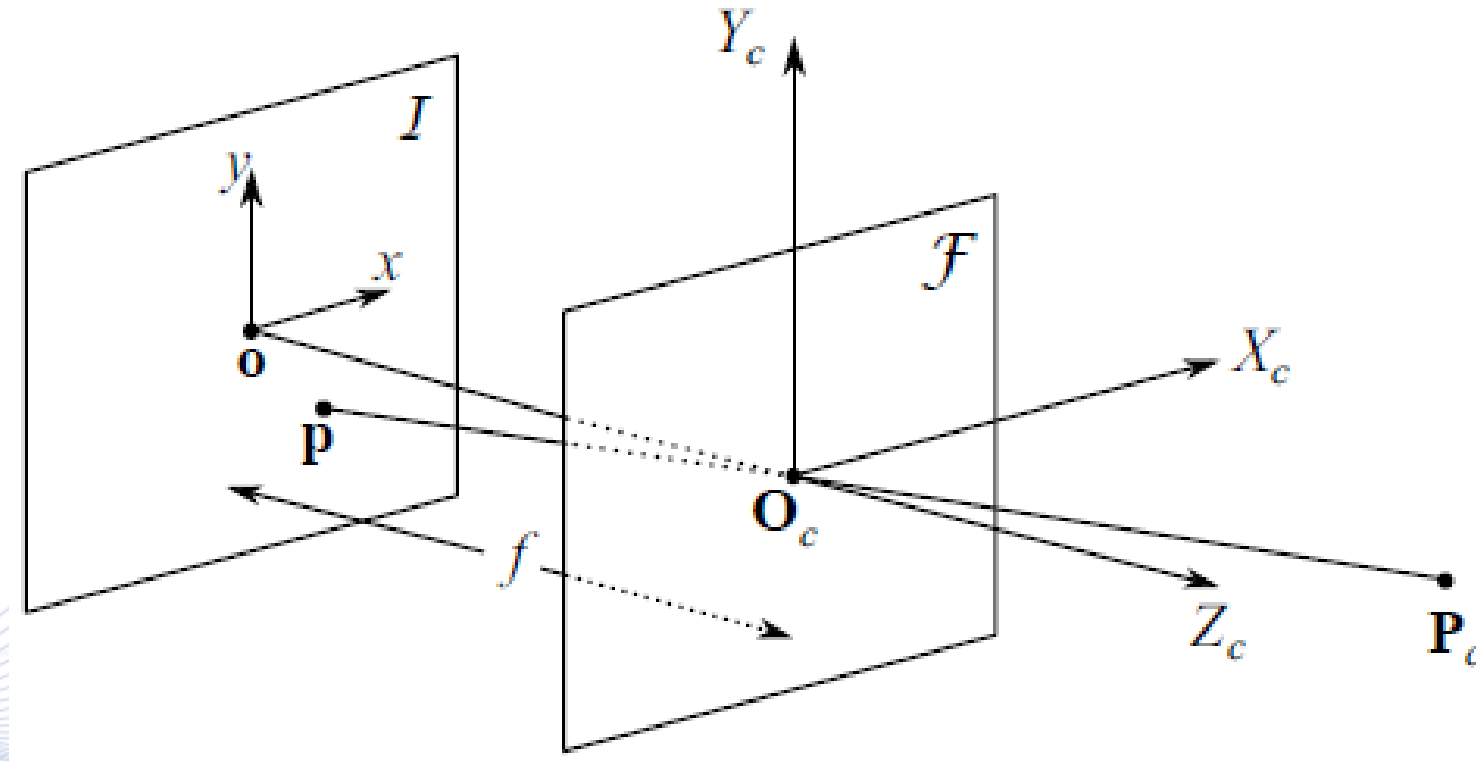

Depiction of focal length  $f$ .

# Camera Structure

- There are two kinds of lenses:
  - Fixed focal length (e.g., ***prime lens***) and
  - Variable focal length (e.g., ***zoom lens***).

# Camera Structure

- Based on their focal length, lenses are categorized in wide-angle, normal and telephoto lenses:
  - **Wide-angle lens** has smaller focal length than normal, thus capturing wider parts of the scene and exaggerating differences in the relative distance and size between foreground and background objects.
  - **Telephoto lens** has larger focal length and can take photos from a distance.

# Camera Structure

- **Manual camera focusing** can be performed by rotating the camera **focus ring** that moves the lens for better focus.
  - It is useful for close-ups and low-illumination conditions.
- **Camera autofocusing** can be performed by using the camera CCD sensor, a control system and a motor to automatically focus on a selected image point or region.

# Camera Structure

- **Shutter** opens and closes to control the time interval during which light rays can hit the CCD or CMOS chip.
- **Shutter speed** determines shutter open/close duration and determines the amount of incoming light.
- Higher speed is required for capturing unblurred, fast moving scenes, while lower speed is used in night shooting, along with bigger camera **aperture** size.



# Camera Structure

- Aperture size is usually expressed in ***f-numbers***. The bigger the f-number the smaller the aperture size.
- It controls the ***Depth of Field (DOF)***, the distance between the nearest and farthest focused objects in the image.
- The smaller the aperture size is, the longer the depth of field, since less light rays are captured on the image for each visible 3D scene point.

# Camera Structure

**Camera flash** is a source of artificial light required when natural light is limited, or when employing in a small aperture size.

**Viewfinder** allows the photographer to frame the image.

- Digital cameras may have an optical and/or an electronic viewfinder.
- **Optical viewfinders** are telescopes that display the camera field of view.
- **Electronic viewfinders** are LCD display devices doing the same thing by displaying the acquired image.

# Camera Structure

- The ***pentaprism*** is a five-sided optical glass prism that changes light ray direction by  $90^\circ$  as well as reversing the image so that the viewfinder can perceive it correctly.
- The ***camera mirror*** is used to reflect the image in view through a glass focusing screen to the pentaprism and ultimately to the viewfinder.

# Camera Structure

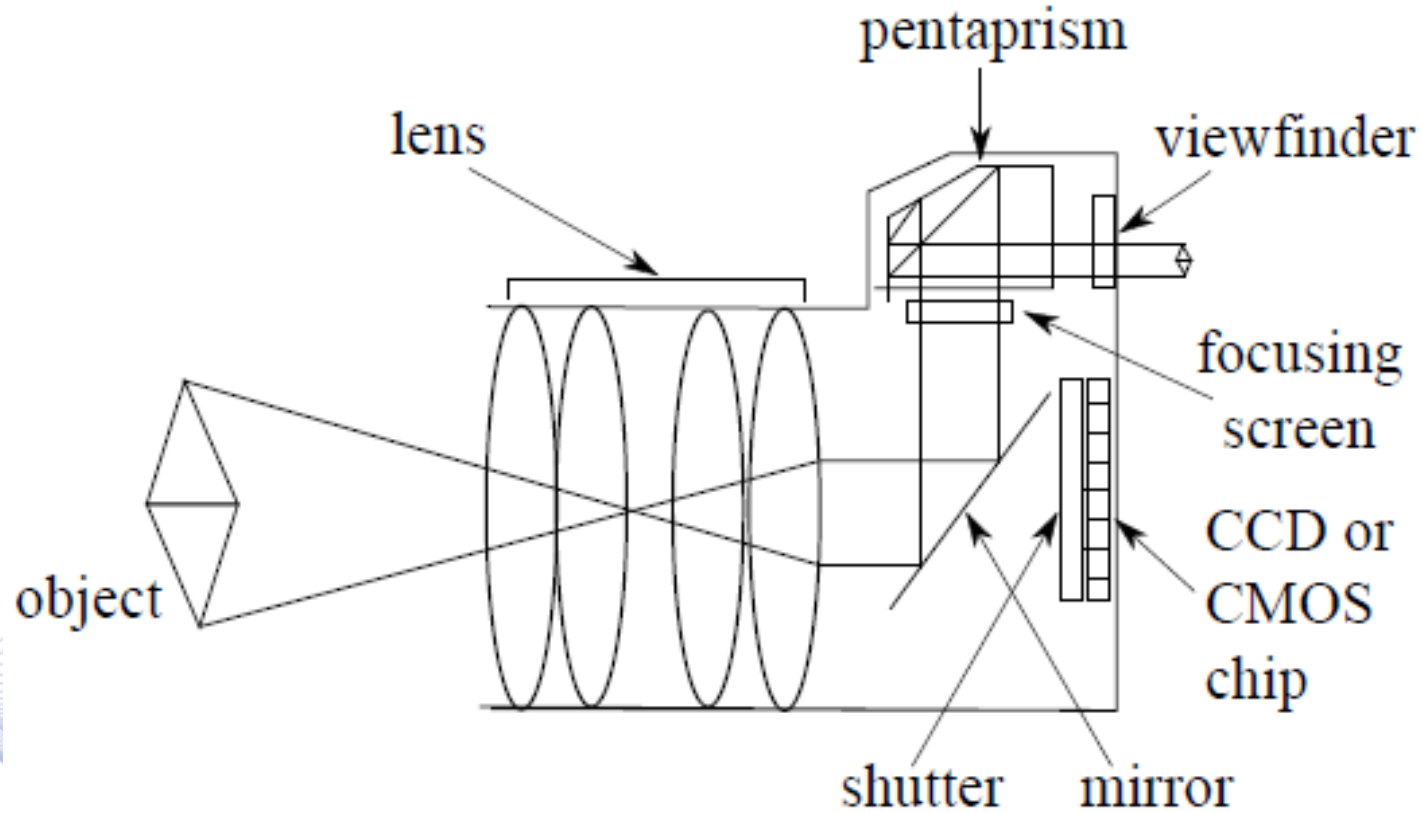

Camera structure.

# Camera Structure



**Color temperature** of a light source is the temperature of a black body (expressed in Kelvin) that emits a light of the same hue to that of the light source.

- Light sources range from warm ones (~1000 K) to cool ones (up to 10000 K).

Temperature In Kelvins	Light Source
1000 – 2000 K	Candle Light
2500 – 3500 K	Tungsten Bulb
3000 – 4000 K	Sunrise/Sunset (clear sky)
4000 – 5000 K	Fluorescent lamps
5000 – 5500 K	Electronic Flash
5000 – 6500 K	Daylight with clear sky
6500 – 8000 K	Moderately overcast sky
9000 – 10000 K	Shade or heavily overcast sky

# Camera Structure

**White balance (WB)** is a process of great importance in getting true color images, as realistic as possible, while avoiding the undesirable color hues, usually caused by the various light sources of different color temperatures.

- In the case of cool lightning sources (blue/green) WB is required to warm colors up, or in the case of warm lightning sources (red/orange) to cool them down.

# Camera Structure



- Almost every camera and post-processing software come with the ***Auto White Balance (AWB)*** option.
- With AWB, the camera evaluates the scene that is being photographed and decides on the best white balance to use.
- It will typically reference a neutral color in the scene, such as white or grey, to determine the correct white balance.
- When using AWB in camera, the results vary, depending on the lighting conditions the shot was taken.
- Mixed lighting can trouble AWB. The use of WB balance post-processing might be mandatory.

# Camera Structure



Image before white balance.

Image after white balance.



# Camera Types

- **Single Lens Reflex** cameras have a mirror between the shutter and the lens.
- **Twin Lens Reflex** cameras have two lenses with the same focal distance, one for taking images and the other behaving as a viewfinder. The image shown on the focusing screen and the one created on the semiconductor chip are exactly the same.
- **Mobile phone cameras** has fixed lenses and no physical shutter.

# Camera Types

- **Video cameras** have a similar structure to camera phones.
- **Professional video cameras** are used in digital cinema and television production. They can record HDTV and UHDTV video.
- **Closed-circuit television (CCTV)** cameras are typically small, can be easily hidden and are used in security and surveillance applications.
- **Webcams** usually provide a live video stream to Internet environments. They use cheap plastic lenses.

# Camera Model

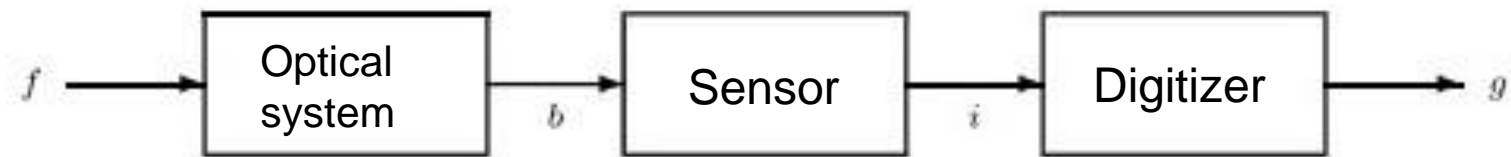
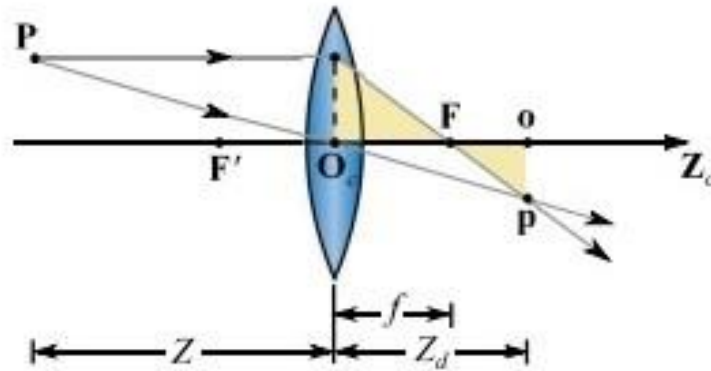

Image acquisition model.

# Optical Lens Models

- The simplest optical systems use **thin lenses**. There are two dominant types of thin lenses, the *converging* and the *diverging* ones.



Graphical model of a thin lens.

# Optical Lens Models



- In a **converging lens**, all light rays entering the lens in parallel to the optical axis converge to a focal point **F** that lies behind the lens.
- In a **diverging lens**, light rays enter the lens in parallel to the optical axis and diverge, in such a way that they appear to diverge from a virtual focal point **F** in front of the lens.
- Converging/diverging lenses have positive/negative focal length  $f$ , respectively.

# Optical Lens Models

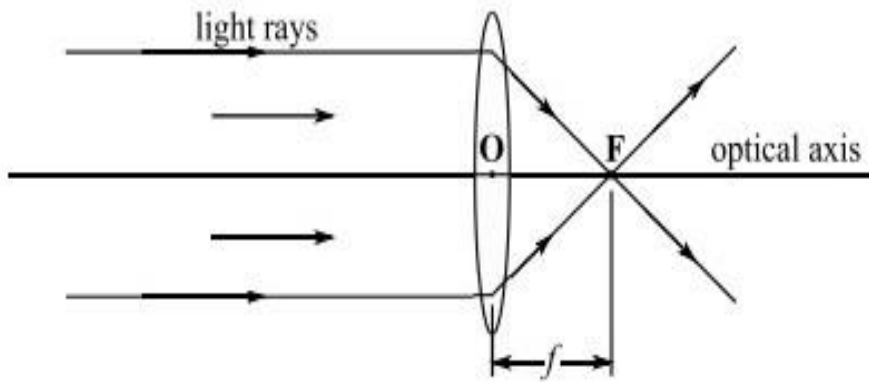

Converging thin lens.

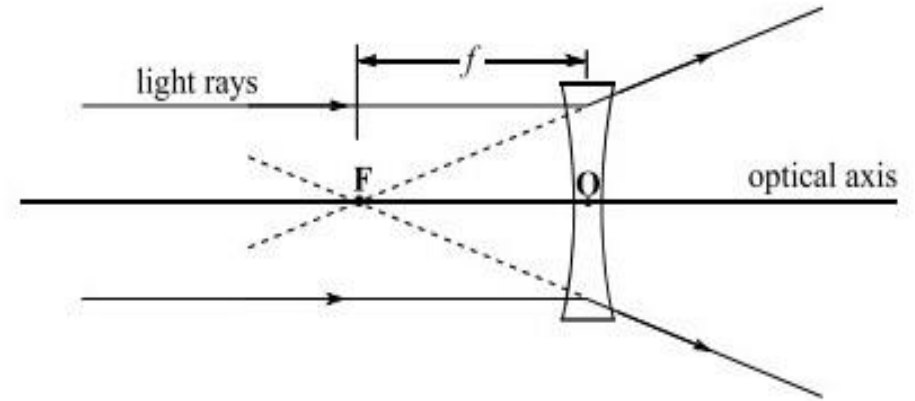

Diverging thin lens.

# Optical Lens Models



## *Fundamental Equation of Thin Lenses:*

$$\frac{1}{Z} + \frac{1}{Z_d} = \frac{1}{f},$$

- $Z$  is the distance of a scene point  $\mathbf{P}$  from the lens along the optical axis.
- $Z_d$  is the distance of its corresponding focused image point  $\mathbf{p}$  from the lens along the optical axis.
- $f$  is the lens focal length.

# Optical Lens Models

- For a thin double-convex lens, having a small diameter in comparison to its focal length,  $f$  is given by the famous ***Lensmaker's equation***.

$$\frac{1}{f} = (n - 1) \left( \frac{1}{R_1} + \frac{1}{R_2} \right),$$

- $n$  is the lens material refractive index.
- $R_1, R_2$  are the radii of the front and rear spherical lens surfaces.



# Optical Lens Models



- **Effective lens diameter**  $d$  describes the part of the lens actually accessible by light rays from the scene.
- Aperture differentiates the effective diameter from the physical diameter of the lens.
- $d$  and  $f$  determine the optical system **Field of View (FOV)**  $\varphi$ :

$$\varphi = \arctan\left(\frac{d}{2f}\right).$$

It defines the portion of the scene the camera actually views.

# Image Formation Models

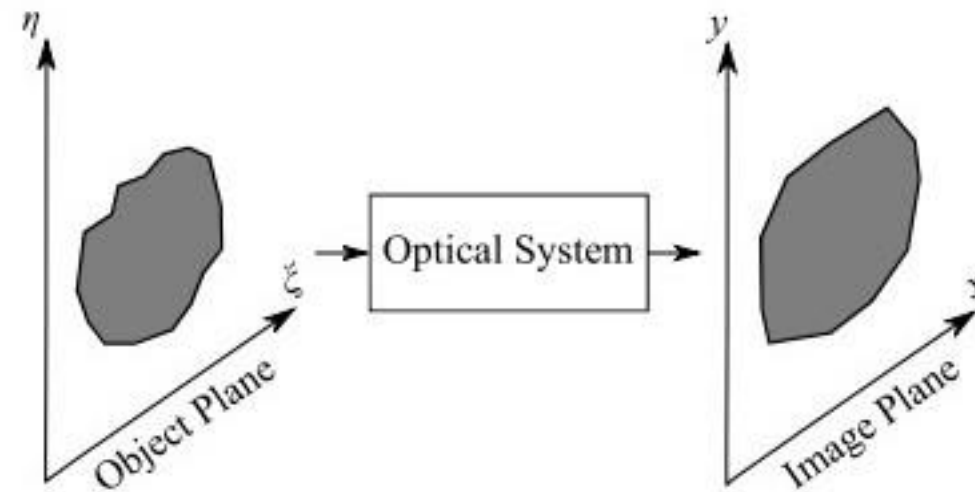

Optical system input and output images.

# Image Formation Models

Both signals  $f(\xi, n)$ ,  $b(x, y)$  represent optical intensities:

- They must take non-negative values, therefore:

$$f(\xi, n) \geq 0, \quad b(x, y) \geq 0.$$

The input-output relation of the optical subsystem is given by a **2D convolution**:

$$b(x, y) = \iint_{-\infty}^{\infty} f(\xi, n) h(x - \xi, y - n) d\xi dn.$$

# Optical sensors

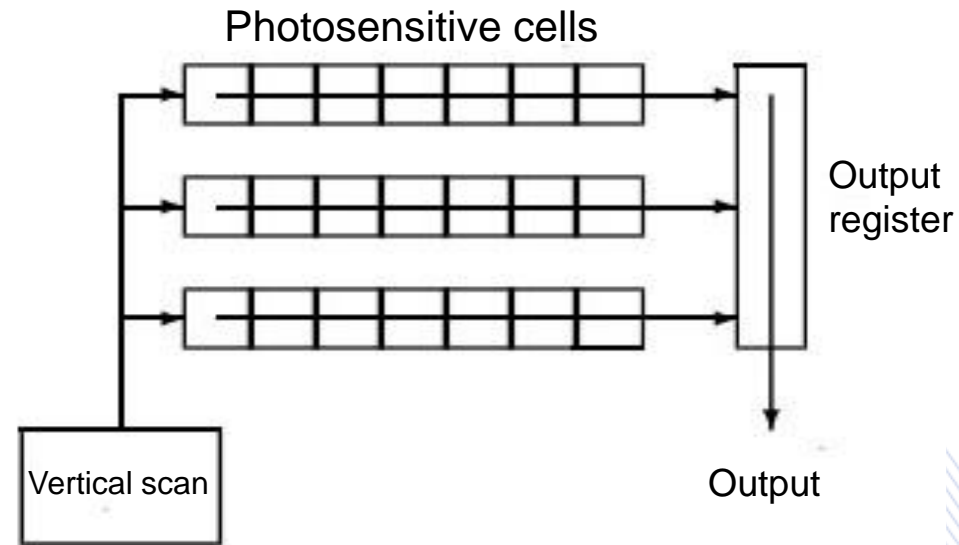

CCD Camera Structure.

# Optical sensors

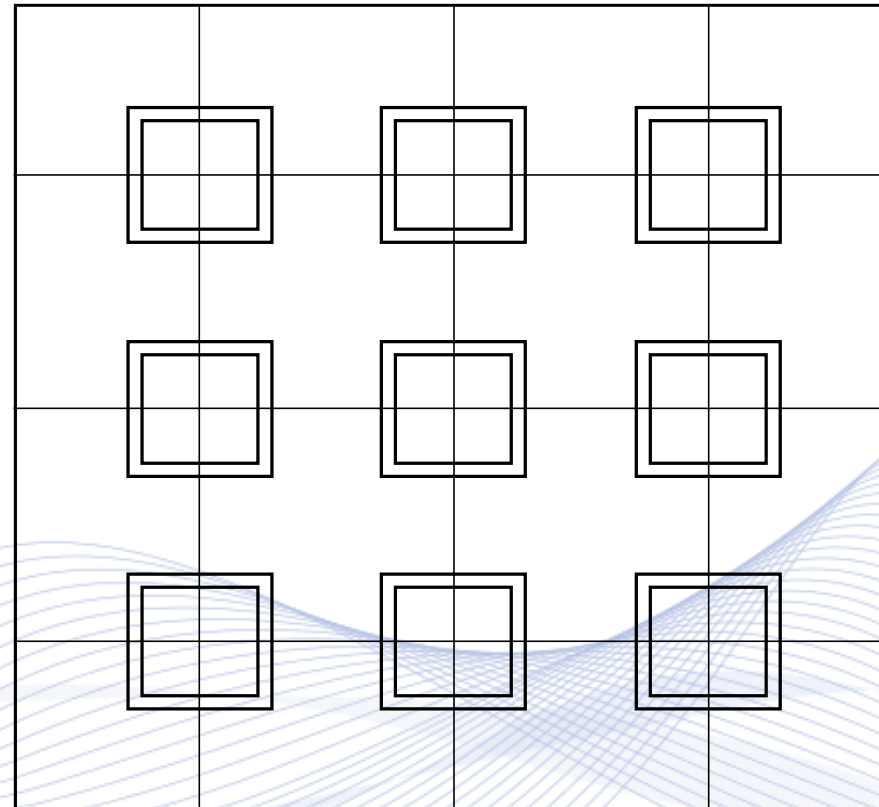

Square CCD cell grid.

# Optical sensors



- **Charge-Coupled Device (CCD)** is the most popular optical sensor technology.
- A three-phase CCD pixel consists of three polysilicon gates vertically oriented towards two channel stops.
- There are some CCD structures which use one, two or four polysilicon gates to define a pixel.
- CCD grid topology can be square or orthorhombic.

# Optical sensors

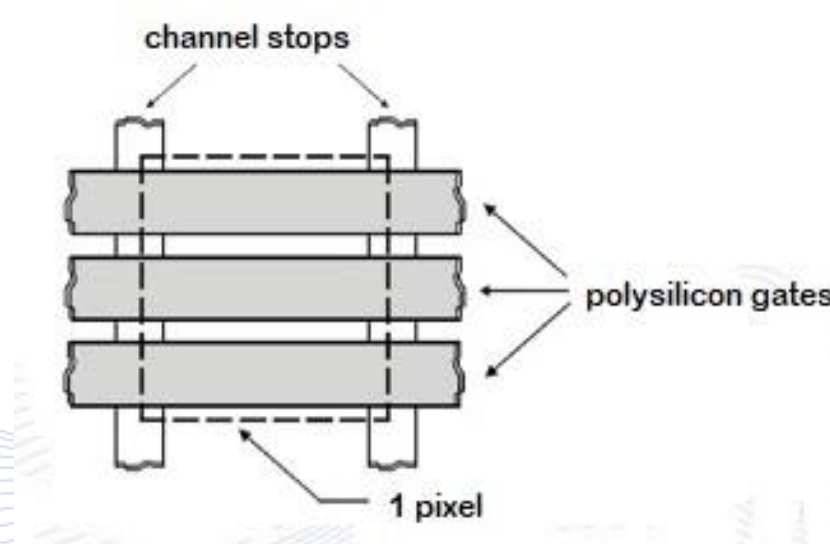

Three-phase CCD cell.

# Optical sensors

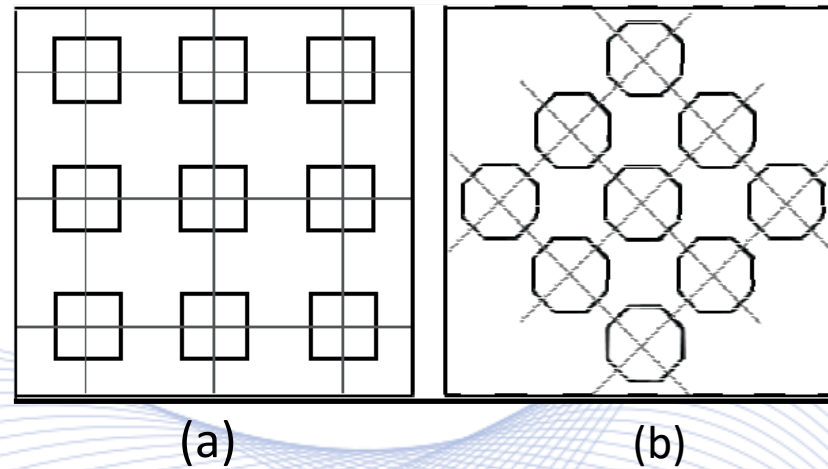

CCD cell grid topologies: (a) square; (b) orthorhombic.



# Optical sensors



- A simplified image recording model with a CCD sensor follows the form:

$$i = g^\gamma (b + n)^\gamma,$$

- $b, i$ : input and output (recorded) image brightness.
- $g$ : **sensor gain** (can be set automatically).
- $\gamma$ : sensor  **$\gamma$  coefficient** determining sensor nonlinearity. It can be evaluated for each sensor. In many cameras, it is in the range  $[0.55, 1.00]$ .
- $n$ : CCD noise.

# Optical sensors

- $b$ : input luminance.
- $i$ : output current.

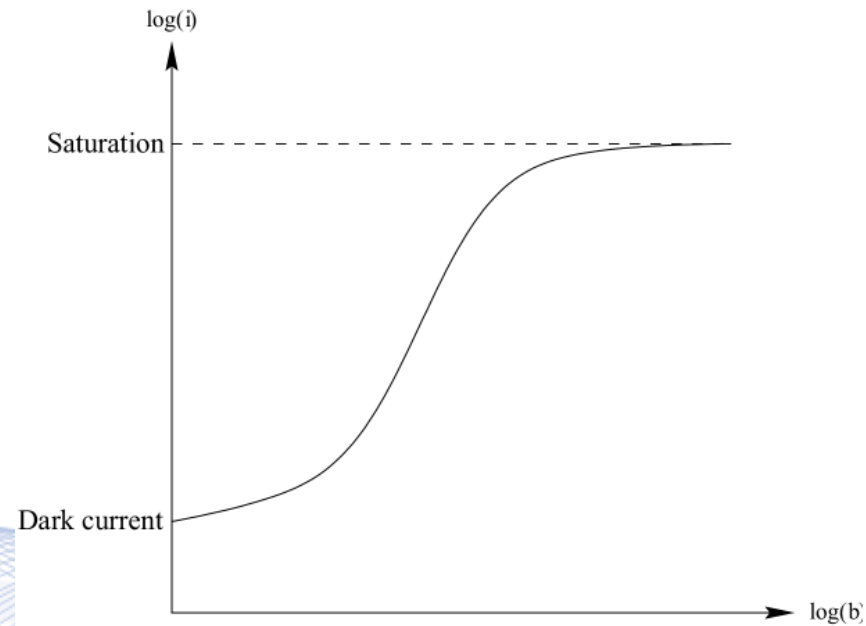

Characteristic curve of the light sensor.

# Image scanners

- **Image scanners** are devices that optically scan images and texts and convert them to digital images. Scanners can be used in the everyday life for simple work office and gaming, but also for reverse engineering and orthotics.
- An **image sensor** is a sensor that detects and conveys information used to make a digital image. It converts the variable attenuation of light waves into signals.

# Image scanners

- **CCD sensors** are frequently used in image scanners. However the last years they are gradually being replaced by CMOS sensors.
- A **Contact Image Sensor (CIS)** is a sensor that is almost in direct contact with the object to be scanned.
- CIS devices produce lower image quality, in comparison to CCD devices.
- They are smaller and lighter, therefore more suitable for *portable scanners*.

# Image scanners

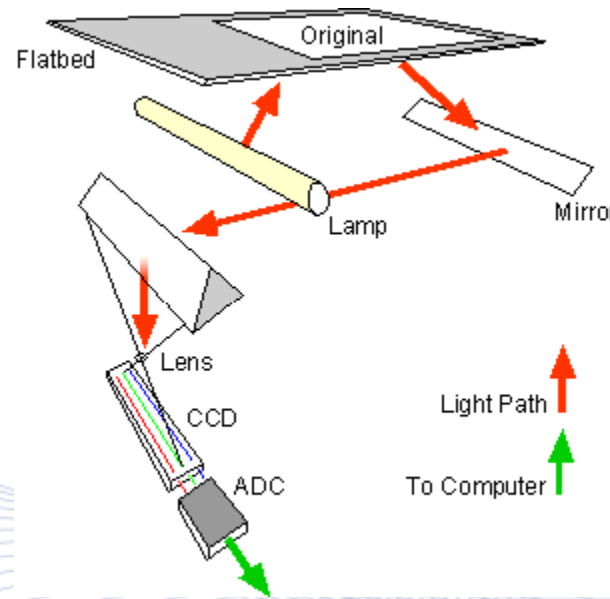

Scanner structure [CIR].

# Image scanners



- The previously mentioned technologies can be implemented in the commonly known ***flatbed scanner***.
- ***Flatbed scanners*** work by shining light onto the object to be scanned and reading the intensity and color of light that is reflected from it.
- In the *biomedical research area*, detection devices for DNA microarrays are called scanners as well. These scanners are high-resolution systems (*up to 1  $\mu\text{m}$ / pixel*), similar to microscopes. The detection is done via CCD or a ***photomultiplier tube***.

# Image scanners

- **Drum Scanners** capture information with **photomultiplier tubes** (PMT), which are light detectors that convert incident photons into an electrical signal.
  - They offer superior *dynamic range* and can extract more detail from dark shadow areas of a transparency.
  - Most drums scanners pass light from halogen lamps through a focusing system to illuminate both reflective and transmissive originals.

# $\gamma$ Correction



In most digital cameras, output image intensity is non-linearly related to their actual image intensity:

$$v_c = b_c^{\gamma_c},$$

- $b_c$  is the actual image intensity.
- $v_c$  is the camera output.

In most imaging devices, the input  $v_d$  is non-linearly related to its depicted light intensity  $b_d$ :

$$v_d = b_d^{\gamma_d}.$$



# $\gamma$ Correction



- In order to appropriately depict image intensity and color, a reverse operation needs to be applied to the camera output, before a digital image can be depicted:

$$v_d = v_c^{\frac{1}{\gamma_c \gamma_d}},$$

- $v_c$  is the camera output brightness,
- $v_d$  is the  **$\gamma$ -corrected image**.
- In colored images,  $\gamma$  correction is more complicated, as it needs to be applied on all three **RGB** channels.

# $\gamma$ Correction



Before gamma correction.



After gamma correction.

# Digital Image Formation

- Image formation
- Optical sensors and cameras
- **Image digitization**
- Image noise

# Digital Image Formation

## ***Sampling and digitization:***

- They are performed by an  $A/D$  converter (in a frame grabber).
- It transforms the analog image  $i(x, y)$  to a digital image:

$$i(n_1, n_2) = i(n_1T_1, n_2T_2), \quad n_1 = 1, \dots, N, \quad n_2 = 1, \dots, M.$$

# Image digitization

## Quantization:

- It is performed by the  $A/D$  converter;
- $q$ : quantization step  $q = \frac{1}{2^b}$ ;
- quantized image illumination levels  $kq, k = 0, 1, 2, \dots, 2^b - 1$ .

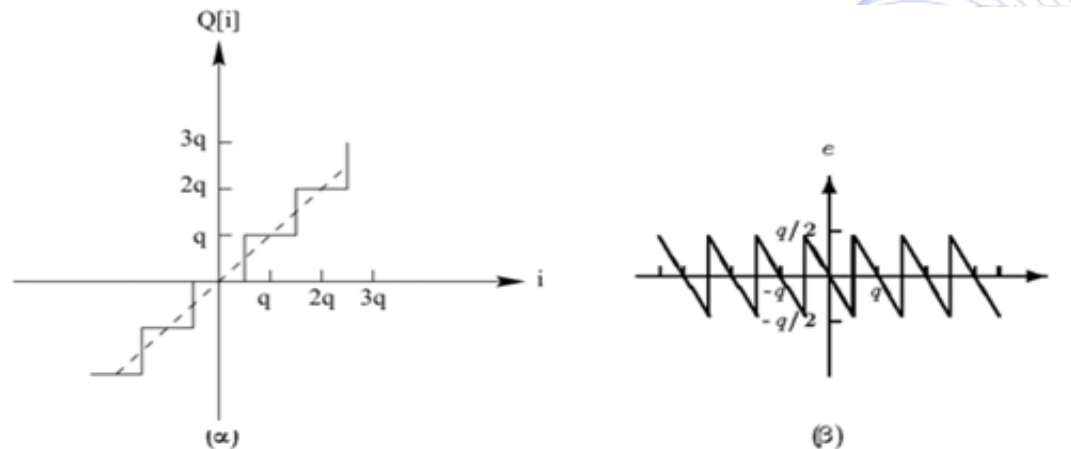

a) Input-output curve of quantizer; b) Quantization error.

# Image digitization

- Image quantization error:

$$e(n_1, n_2) = i(n_1, n_2) - Q[i(n_1, n_2)].$$

- $Q[i]$  is the **quantization function**.
- $P_i, P_e$ : image and error signal power:

$$P_e = \frac{1}{q} \int_{-q/2}^{q/2} (-i)^2 di = \frac{q^2}{12} = 2^{-2b} / 12.$$

- **Signal to Noise Ratio (SNR)** in dB:

$$SNR = 10 \log_{10} \frac{P_i}{P_e} = 10 \log_{10} P_i + 10.79 + 6.02b.$$

# Image digitization

- **Grayscale** images are quantized at 256 levels:
  - 1 byte (8 bits) for pixel representation.
- **Binary** images have only two quantization levels: {0,1}.
  - They are represented with 1 bit per pixel.

# Image digitization



(a)



(b)



(c)



(d)

(a) Original image at 256 grayscale levels; (b) 64 levels;  
(c) 8 levels; (d) 2 levels.



# Image digitization

- A digital image can be represented as a matrix  $\mathbf{i}$  having dimensions  $N \times M$  elements (pixels):

$$\mathbf{I} = \begin{bmatrix} i(1,1) & \cdots & i(1,M) \\ \vdots & \ddots & \vdots \\ i(N,1) & \cdots & i(N,M) \end{bmatrix},$$

or as a vector of  $NM$  elements:

$$\mathbf{i} = [i(1,1), \dots, i(1,M), \dots, i(N,M)]^T.$$

- Vector representation facilitates symbolism in several complex digital image processing methods. Examples will be referred in the next few slides.

# Image digitization

- Image addition is symbolized by:

$$\mathbf{s} = \mathbf{i} + \mathbf{f}.$$

- A non-linearity  $r(i)$  without memory can be represented as:

$$\mathbf{s} = r(\mathbf{i}).$$

- Linear convolutions can be embedded in cyclic convolutions.

- A 2D cyclic convolution operator  $h$  having input and output images, both of size  $N \times M$ , can be represented by a matrix  $\mathbf{H}$  of size  $NM \times NM$ :

$$\mathbf{s} = \mathbf{H}\mathbf{f}.$$

# Image digitization

- **Block circulant** matrix  $\mathbf{H}$  is of the form:

$$\mathbf{H} = \begin{bmatrix} \mathbf{H}_0 & \mathbf{H}_{M-1} & \dots & \mathbf{H}_2 & \mathbf{H}_1 \\ \mathbf{H}_1 & \mathbf{H}_0 & \mathbf{H}_{M-1} & \dots & \mathbf{H}_2 \\ \vdots & \mathbf{H}_1 & \mathbf{H}_0 & \dots & \mathbf{H}_2 \\ \mathbf{H}_{M-2} & \vdots & \vdots & \dots & \mathbf{H}_{M-1} \\ \mathbf{H}_{M-1} & \mathbf{H}_{M-2} & \dots & \mathbf{H}_1 & \mathbf{H}_0 \end{bmatrix}$$

- Each of its submatrices is **circulant**.

$$\mathbf{H}_j = \begin{bmatrix} h_e(j,0) & h_e(j,N-1) & \dots & h_e(j,2) & h_e(j,1) \\ h_e(j,1) & h_e(j,0) & h_e(j,N-1) & \dots & h_e(j,2) \\ \vdots & h_e(j,1) & h_e(j,0) & \dots & \vdots \\ h_e(j,N-2) & \vdots & \vdots & \dots & h_e(j,N-1) \\ h_e(j,N-1) & h_e(j,N-2) & \dots & h_e(j,1) & h_e(j,0) \end{bmatrix}$$

# Image digitization



- If  $\mathbf{f}$  is an image,  $\mathbf{H}$  is the optical transmission convolution operator and  $r(f)$  is the non-linearity of recording, image recording mathematical model is as follows:

$$\mathbf{i} = r(\mathbf{H}\mathbf{f}).$$

# Probabilistic Image Description

- In many cases, it is useful to estimate a probabilistic characterization of an image. In this case we assume that each pixel is a random variable.
- The image vector has a probability distribution of the form:

$$p(\mathbf{i}) = p\{i(1,1), \dots, i(N, M)\}.$$

- If the probability distribution is Gaussian, it is of the form:

$$p(\mathbf{i}) = (2\pi)^{-\frac{NM}{2}} |C_i|^{-\frac{1}{2}} e^{\{-\frac{1}{2}(\mathbf{i}-\mathbf{m}_i)^T C_i^{-1}(\mathbf{i}-\mathbf{m}_i)\}}.$$

# Probabilistic Image Description

- $\mathbf{m}_i$ : expected image intensity (average intensity)
- $\mathbf{C}_i$ : image covariance matrix.
- $|\mathbf{C}_i|$ : covariance matrix determinant.
- A probabilistic image has an expected image intensity  $\mathbf{m}_i$ :

$$\mathbf{m}_i = E \{ \mathbf{i} \} = [E \{ i(n_1, n_2) \}]^T.$$

and an autocorrelation matrix  $\mathbf{R}_i$  of dimensions  $NM \times NM$ :

$$\mathbf{R}_i = E \{ \mathbf{i} \mathbf{i}^{*T} \} = [E \{ i(n_1, n_2) i^*(n_3, n_4) \}].$$

# Probabilistic Image Description

- **Autocovariance matrix**  $\mathbf{C}_i$  is given by the expression:

$$\mathbf{C}_i = \mathbf{R}_i - \mathbf{m}_i \mathbf{m}_i^{*T}$$

- Linear systems theory postulates that if an image  $\mathbf{i}$  passes through an LSI system having a transfer function  $\mathbf{H}$ , then the expected vector  $\mathbf{m}_s$  and the auto-correlation matrix  $\mathbf{R}_s$  of the output  $\mathbf{s}$  are given by the expressions:

$$\mathbf{m}_s \triangleq E\{\mathbf{s}\} = \mathbf{H}\mathbf{m}_i$$

$$\mathbf{R}_s \triangleq E\{\mathbf{s}\mathbf{s}^{*T}\} = \mathbf{H}\mathbf{R}_i\mathbf{H}^{*T}.$$

# Digital Image Formation

- Image formation
- Optical sensors and cameras
- Image digitization
- **Image noise**



# Image generation noise

- Digital image corruption by noise:
  - during a) image acquisition or b) image transmission.
- Image acquisition noise:
  - photoelectronic noise;
  - film-grain noise (signal-dependent).
- Image formation model:

$$g(x, y) = c(f(x, y))^{\gamma} n(x, y).$$

# Image generation noise

Noisy image acquisition model:

$$g(x, y) = c_2(h(x, y) ** f(x, y))^{\gamma} + (c_2(h(x, y) ** f(x, y))^{\gamma})^{1/2}n(x, y) + n_t(x, y).$$

- $f(x, y)$ : original image to be recorded.
- $g(x, y)$ : observed image.
- $h(x, y)$ : transfer function of the optical subsystem.
- $n(x, y)$ : ***multiplicative noise***.
- $n_t(x, y)$ : ***additive noise***.

# Image generation noise

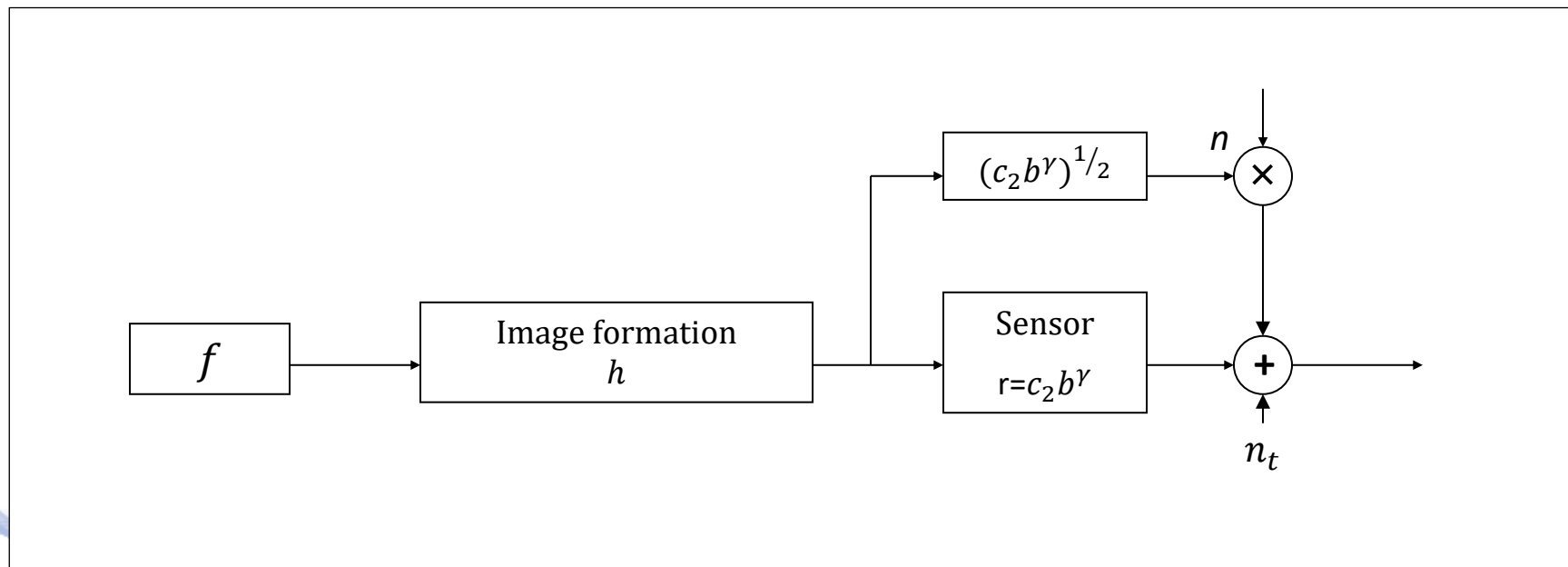

Image formation model.

# Image noise generators

Artificial noise generation is needed for:

- Simulations
- Certain artistic applications (e.g. for the simulation of film-grain noise).
- Noise  $n(i, j)$  generation:
  - Random number generators: uniform noise in  $[0,1]$ .
  - Noise transformation to a different pdf, e.g., Gaussian or Laplacian.

# Image noise generators

- Additive/multiplicative image noise:

$$g(i, j) = f(i, j) + n(i, j),$$

$$g(i, j) = f(i, j)n(i, j).$$

- **Salt-pepper noise** consists of black and/or white image impulses, atmospheric or man-made (e.g. car engines sparkles):

$$g(i, j) = \begin{cases} z(i, j) & \text{with probability } p. \\ f(i, j) & \text{with probability } 1 - p. \end{cases}$$

# Image noise generators

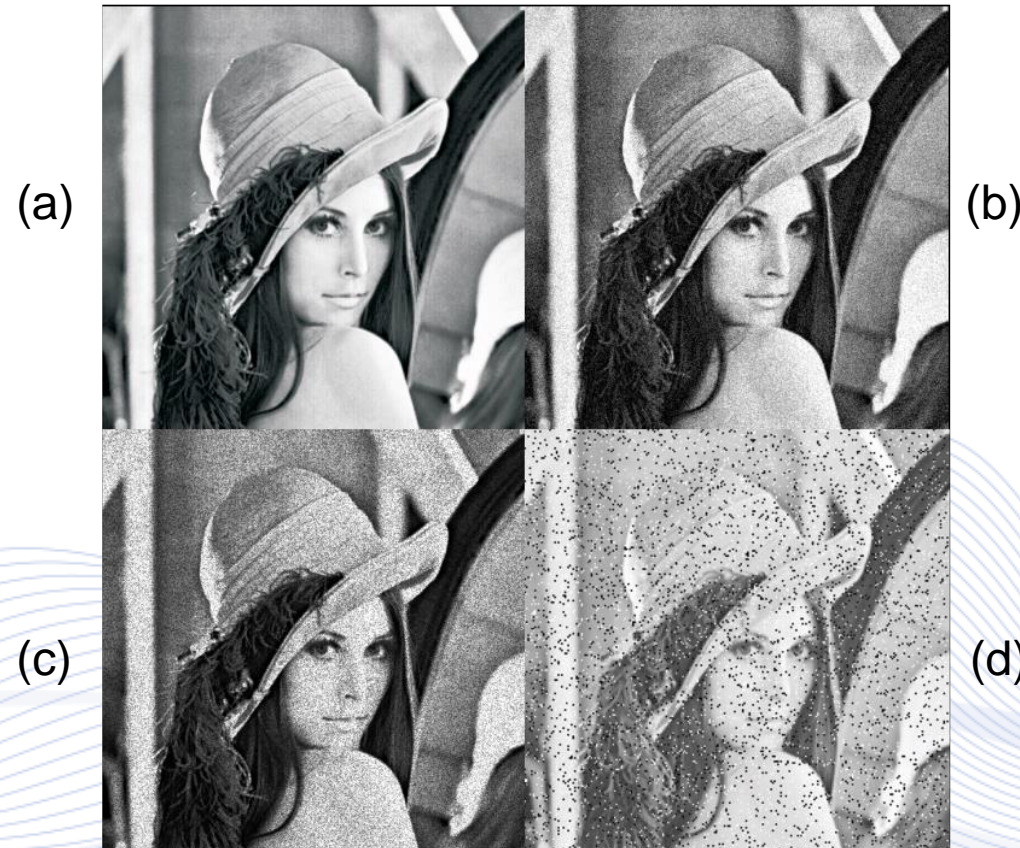

(a) Original image; (b) Image corrupted by additive Gaussian noise; (c) Image corrupted by multiplicative Gaussian noise; (d) image corrupted by salt-pepper noise.

# Image noise generators

- A random variable  $X$  having uniform noise distribution  $U(0,1)$   $f_X(x) = 1, x \in [0,1]$  can be generated using random number generator routines.
- It can be transformed to random variable  $Y$ , using a nonlinear transformation  $Y = g(X)$ , where  $g(x)$  is differentiable. If  $x_i$  are solutions of  $y = g(x)$ , then:

$$f_Y(y) = \sum_i \frac{f_X(x_i)}{|g'(x_i)|}$$

# Image noise generators

- Uniform noise data can be transformed to data following a normal (Gaussian) distribution  $N(0,1)$ :

$$f_Y(y) = \frac{1}{\sqrt{2\pi}} \exp\left\{-\frac{y^2}{2}\right\}$$

using the following nonlinear transformation:

$$Y = -\frac{\ln\left(\frac{1}{X}-1\right)}{1.702}.$$



# Image noise generators

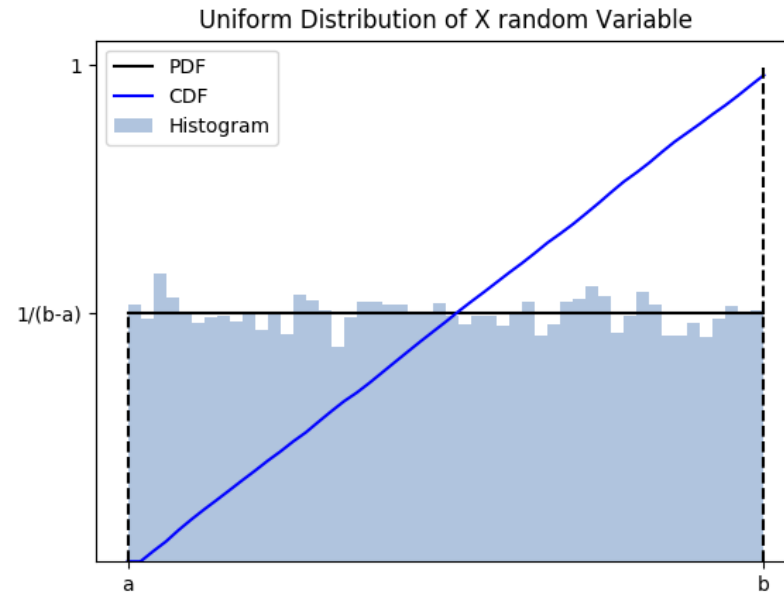

Uniform random number generation in  $[0,1]$ .

# Image noise generators

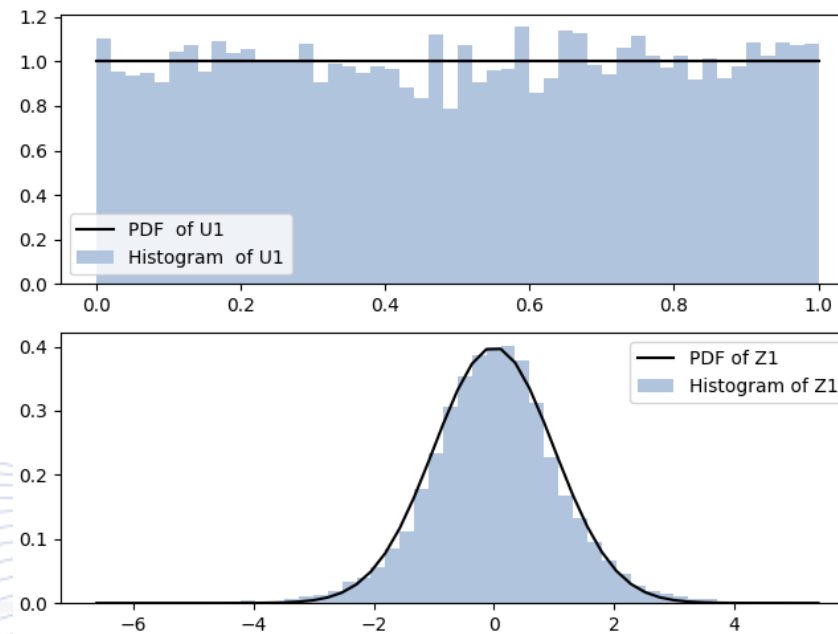

Gaussian random number generation using uniform distribution.

# Image noise generators

- Transformation of uniform noise distributed in  $[0,1]$  to a Laplacian probability distribution:

$$f_Y(y) = \frac{1}{2} e^{-|y|}.$$

can be done using the transformation:

$$Y = \begin{cases} \ln(2X), & 0 \leq X \leq 1/2. \\ -\ln(2 - 2X), & 1/2 \leq X < 1. \end{cases}$$

# Random Number Generation

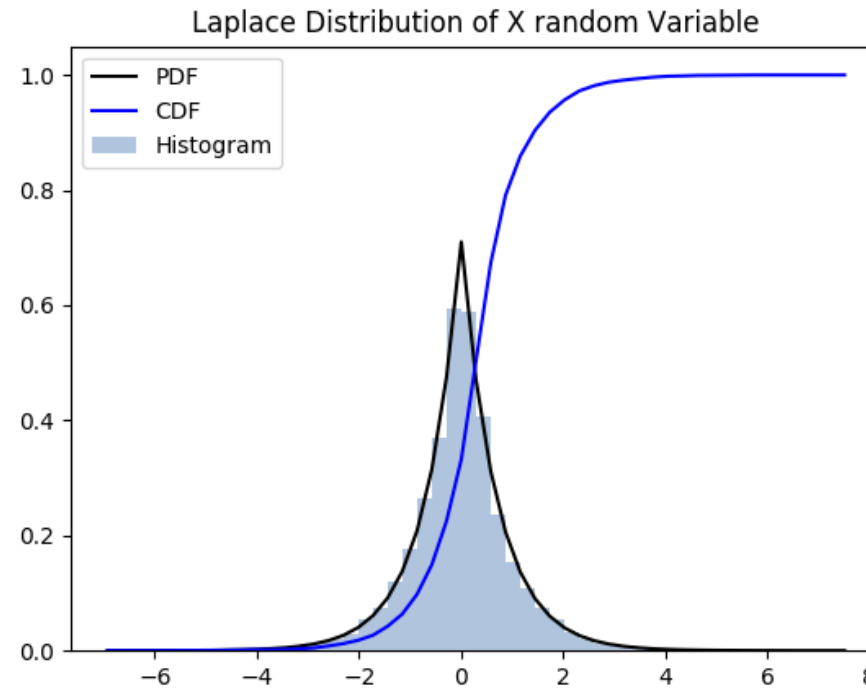

Laplacian random number generator histogram.

# Image noise generators

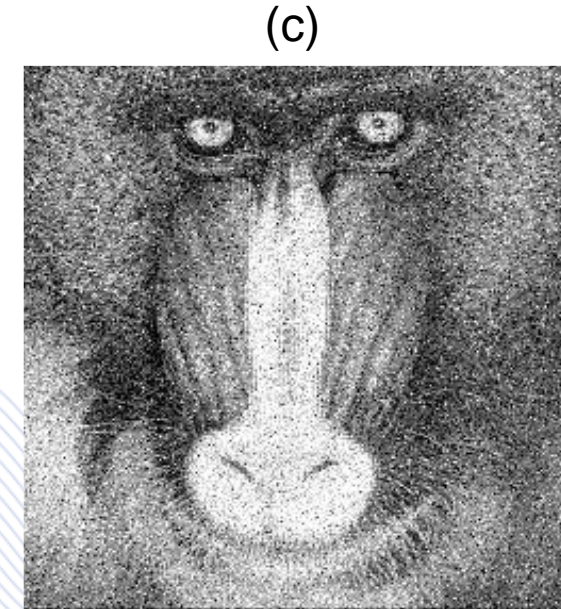
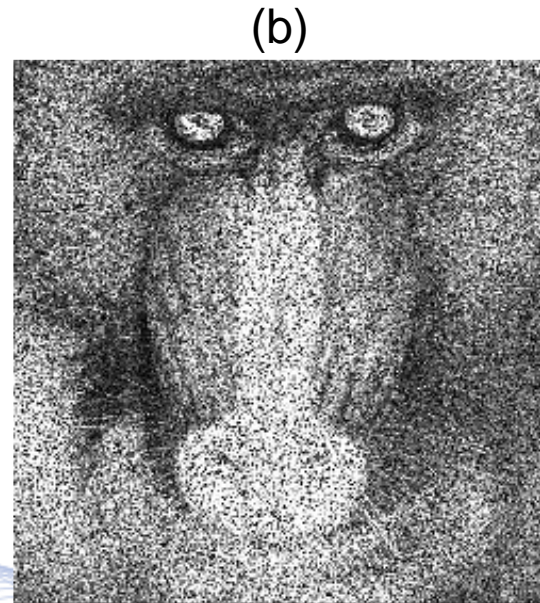
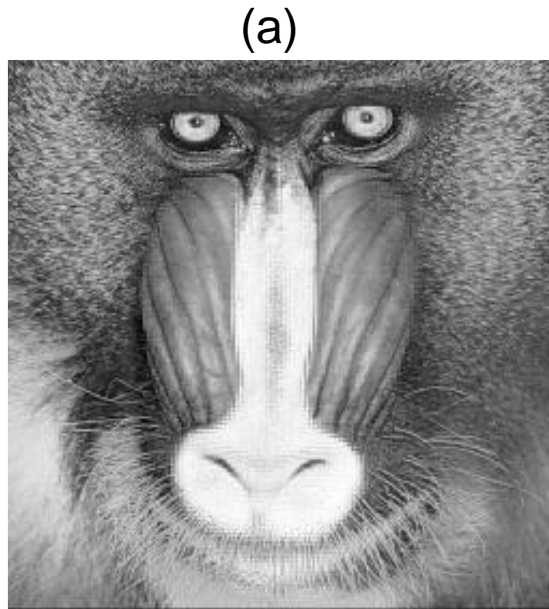

(a) Original image; (b) Image corrupted by multiplicative Gaussian noise; (c) image corrupted by additive Laplacian noise.

# Bibliography

- [PIT2021] I. Pitas, “Computer vision”, Createspace/Amazon, in press.
- [PIT2017] I. Pitas, “Digital video processing and analysis” , China Machine Press, 2017 (in Chinese).
- [PIT2013] I. Pitas, “Digital Video and Television” , Createspace/Amazon, 2013.
- [NIK2000] N. Nikolaidis and I. Pitas, “3D Image Processing Algorithms”, J. Wiley, 2000.
- [PIT2000] I. Pitas, “Digital Image Processing Algorithms and Applications”, J. Wiley, 2000.

# Q & A

**Thank you very much for your attention!**

**More material in  
<http://icarus.csd.auth.gr/cvml-web-lecture-series/>**

**Contact: Prof. I. Pitas  
[pitass@csd.auth.gr](mailto:pitass@csd.auth.gr)**